



### BATTERY MODULE

- Two Mounting Options: DIN-Rail or Panel/ Wall Mounting
- Small Mounting Footprint
- 2m Power Leads Included
- Heavy Duty Fuse Holder and Spare Fuse Included
- 3 Year Warranty, Except for Batteries, Which Are Considered a Service Part.

## 1. GENERAL DESCRIPTION

The UZK12.072 battery module utilizes one non-spillable maintenance-free VRLA lead-acid battery, which is assembled in a package with all wiring and fusing included.

The battery module is available in two different options. It can be ordered as UZK-module with a battery or as UZO-module without a battery which can be installed at a later date to avoid outdated batteries.

The battery module can either be mounted on a DIN-rail or be screwed on a flat surface.

## 2. SHORT-FORM DATA

Nominal voltage	DC 12V	
Nominal battery capacity	7Ah	
Nominal battery life	3 to 5 years	According EUROBAT
Battery current	Max. 30A Max. 1.8A	Discharging current Charging current
Recommended charging voltage	13.9V 13.75V 13.6V 13.45V	At 10°C At 20°C At 30°C At 40°C
Self-discharge rate	3%/month	At 20°C
Battery fuse	30A	ATOF® 287 030 from Littelfuse
Temperature range	-10°C to +40°C -15°C to +50°C	For charging For discharging
Size (WxHxD)	158x132x98mm	WxHxD
Weight	3500g / 7.7lb 800g / 1.76lb	For UZK12.072 For UZO12.072

## 3. ORDER NUMBERS

Battery Module	<b>UZK12.072</b>	Battery module with assembled batteries
	<b>UZO12.072</b>	Battery module without assembled batteries
	UZB12.071	Battery replacement 12V, 7Ah

## 4. MARKINGS



### INDEX

	Page		Page
1. General Description .....	1	11. Environment .....	5
2. Short-form Data .....	1	12. Protection Features .....	5
3. Order Numbers .....	1	13. Approvals .....	6
4. Markings .....	1	14. Other Fulfilled Standards .....	6
5. Intended Use .....	3	15. Physical Dimensions and Weight .....	7
6. Instructions for Disposal of the Batteries .....	3	16. Wall/ Panel Mounting .....	8
7. Instructions for Battery Storage .....	3	17. Recommendations for a Long Battery Life .....	9
8. Installation Instructions .....	3	18. Mounting Orientations .....	10
9. Hazardous Location Installation Instructions .....	4		
10. Instructions for Replacing Batteries .....	5		

The information given in this document is correct to the best of our knowledge and experience at the time of publication. If not expressly agreed otherwise, this information does not represent a warranty in the legal sense of the word. As the state of our knowledge and experience is constantly changing, the information in this data sheet is subject to revision. We therefore kindly ask you to always use the latest issue of this document (available under [www.pulspower.com](http://www.pulspower.com)).

No part of this document may be reproduced or utilized in any form without our prior permission in writing.

**⚠ WARNING** Risk of electrical shock, fire, personal injury or death.

- Turn power off before working on the device. Protect against inadvertent re-powering.
- Do not modify or repair the unit.
- Use caution to prevent any foreign objects from entering the housing.
- Do not use in wet locations or in areas where moisture or condensation can be expected.
- Do not touch during power-on, and immediately after power-off. Hot surfaces may cause burns.

## 5. INTENDED USE

This module is designed for installation in an enclosure and is intended for the general professional use such as in industrial control, office, communication, and instrumentation equipment.

Do not use this module in equipment, where malfunction may cause severe personal injury or threaten human life.

## 6. INSTRUCTIONS FOR DISPOSAL OF THE BATTERIES

Batteries must be completely discharged before replacement and can be returned to the supplier of the battery module or the battery manufacturer for disposal.

Always dispose batteries through a recycling organization.

## 7. INSTRUCTIONS FOR BATTERY STORAGE

Do not store batteries or battery modules at temperatures higher than 25°C or performance and lifetime may change.

Do not store discharged batteries. Keep batteries fully charged!

Charge retention is important to get the longest battery life. Stored batteries which are not fully charged age faster than charged batteries.

Do not store batteries longer than 9 months without charging or performance and lifetime may change. Every 9 months or whenever the open circuit voltage (OCV) falls below 12.6V, the battery module should be charged. Apply a charging voltage of 13.8V (at 25°C) for 72 hours. Batteries with an OCV below 12V must not be charged anymore and must be disposed.

## 8. INSTALLATION INSTRUCTIONS

This device may only be installed and put into operation by qualified personnel.

Before initial use, check the last charging which is marked on the battery. If it is older than 9 month, replace the battery.

Do not install the battery fuse until the installation work is complete.

This device does not contain serviceable parts, except the fuse or replacement battery. If malfunction should occur during installation or operation, first check the fuse and battery for proper functionality. If the unit is damaged or if the malfunction continues, immediately turn power off and send device to the factory for inspection.

Replacement fuses must be of the same type or an UL listed fuse with the same nominal value and characteristics.

Do not short-circuit the battery poles or power wires and always check correct battery polarity.

Mount the device onto a heavy duty DIN-rail or screw it securely on a flat surface. Before mounting the unit on a flat surface, detach the DIN-rail slider (remove the plastic lock mechanism by using a flat-blade screwdriver and move the lock downwards while pushing the plastic slide upwards at the same time) and the two aluminum DIN-rail brackets (Torx T10 screwdriver).

Do not install the battery module upside down.

Place the battery module in a cool area inside a cabinet.

Shorten the (+) and (-) wires as needed for the DC-UPS between the battery module and the DC-UPS. If separate wires are used, do not use wires smaller than 4mm<sup>2</sup> (12 AWG).

Install the device in an enclosure providing protection against electrical, mechanical and fire hazards. Ensure sufficient ventilation by following the requirements of the EN 50272-2.

**CAUTION:** The unit contains wet cell batteries. Ventilation of the installation room in accordance with the rules of Canadian Electrical Code, part 1 is required if used in Canada.

The battery module is for use in a controlled environment. Do not use the device in pollution degree 3 areas without additional protection or in applications where a degree of protection better than IP00 is required.

Do not use batteries other than the original batteries supplied by the manufacturer to avoid conflicts with agency approvals.

The maximum surrounding air temperature is +50°C / +122°F. The operational temperature is the same as the ambient or surrounding air temperature and is defined as the air temperature 2cm below the device.

Fig. 8-1 **Wiring scheme**

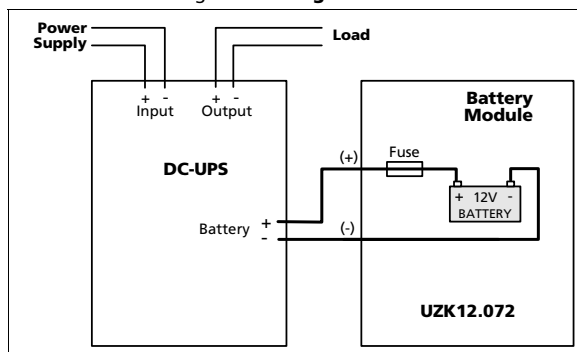

## 9. HAZARDOUS LOCATION INSTALLATION INSTRUCTIONS

The device is suitable for use in Class I Division 2 Groups A, B, C, D locations and for use in Group II Category 3 (Zone 2) environments.

ATEX Certificate: EPS 15 ATEX 1 025 X

ATEX Classification: II 3G EX ec IIC T4 Gc

### **WARNING EXPLOSION HAZARDS!**

Substitution of components may impair suitability for this environment. Do not disconnect the device unless power has been switched off or the area is known to be non-hazardous.

A suitable enclosure must be provided for the end product which has a minimum protection of IP23 and fulfils the requirements of the EN 60079-15. Sufficient ventilation must be ensured in the final installation.

Do not use batteries other than the original batteries supplied by the manufacturer or batteries, which are approved according to EN/ IEC 60079-7.

### 10. INSTRUCTIONS FOR REPLACING BATTERIES

Batteries need to be replaced periodically. The time interval depends on the ambient temperature in which the battery is used and on the number and depth of discharge cycles. In a typical application it is recommended to replace the batteries at least every 2 years.

Disconnect battery fuse before replacing the battery.

Regarding disposal of used batteries see chapter 6.

### 11. ENVIRONMENT

Operational temperature *)	-10°C to +40°C (14°F to 104°F)	For charging Frequently charging below +5°C (41°F) reduced the lifetime of the battery
	-15°C to +50°C (5°F to 122°F)	For discharging
Storage temperature	-20°C to +50°C (-4°F to 122°F)	For storage and transportation Recommendation: Do not store at temperatures higher than 25°C or performance and lifetime may change.
Humidity	5 to 95% r.h.	IEC 60068-2-30 Do not energize while condensation is present
Vibration sinusoidal	±4mm at 16.7Hz fixed frequency for 1hour	Vibration in vertical mounting orientation according to IEC/EN 61056-1
Shock	free fall from 20cm onto a wooden floor	Shock with bottom down orientation according to IEC/EN 61056-1
Altitude	0 to 6000m (0 to 20 000ft)	
Degree of pollution	2	According to IEC 62477-1, not conductive
LABS compatibility	The unit does not release any silicone or other LABS-critical substances and is suitable for use in paint shops.	
Corrosive gases	ISA-71.04-1985, Severity Level G3	

\*) Operational temperature is the same as the ambient temperature and is defined as the air temperature 2cm below the unit.

### 12. PROTECTION FEATURES

Degree of protection	IP 00	According to EN/IEC 60529
Class of protection	III	According to EN/IEC 61140
Internal input fuse	30A	DC-Fuse (blade type) ATOF® 287 030 from Littelfuse Replacement fuses must be of the same type or an UL listed fuse with the same nominal value and characteristics.
Isolation	1100Vac	Isolation voltage between power to chassis

### 13. APPROVALS

EC Declaration of Conformity		The CE mark indicates conformance with the - EMC directive and the - ATEX directive
UL 508		Listed for use as Industrial Control Equipment; U.S.A. (UL 508) and Canada (C22.2 No. 107-1-01); E-File: E198865
ANSI / ISA 12.12.01-2015 Class I Div 2		Recognized for use in Hazardous Location Class I Div 2 T4 Groups A,B,C,D systems; U.S.A. (ANSI / ISA 12.12.01-2015) and Canada (C22.2 No. 213-M1987)
EN 60079-0, EN 60079-7 ATEX	 II 3G Ex ec IIC T4 Gc	Approval for use in hazardous locations Zone 2 Category 3G. Number of ATEX certificate: EPS 15 ATEX 1 025 X The battery module must be built-in in an IP23 enclosure.
IEC 60079-0, IEC 60079-7	<b>IECEX</b>	Suitable for use in Class 1 Zone 2 Groups IIa, IIb and IIc locations. Number of IECEX certificate: IECEX EPS 15.0049X
Marine		GL (Germanischer Lloyd) classified Environmental category: A Marine and offshore applications
EAC TR Registration		Registration for the Eurasian Customs Union market (Russia, Kazakhstan, Belarus)

### 14. OTHER FULFILLED STANDARDS

RoHS Directive	<b>RoHS</b> ✓	Directive 2011/65/EU of the European Parliament and the Council of June 8 <sup>th</sup> , 2011 on the restriction of the use of certain hazardous substances in electrical and electronic equipment. Note: Batteries are exempt from the directive. The directive only applies to the remaining assembly parts of the battery module.
REACH Directive	<b>REACH</b> ✓	Directive 1907/2006/EU of the European Parliament and the Council of June 1 <sup>st</sup> , 2007 regarding the Registration, Evaluation, Authorisation and Restriction of Chemicals (REACH)

### 15. PHYSICAL DIMENSIONS AND WEIGHT

Width	158mm / 6.22"
Height	132mm / 5.2"
Depth	98mm / 3.86"

For DIN-Rail mounting;  
The DIN-rail height must be added to the unit depth to calculate the total required installation depth.

Weight	3500g / 7.7lb	For UZK12.072
	800g / 1.76lb	For UZO12.072

Bracket material	Zinc-plated steel
------------------	-------------------

Fig. 15-1 **Front view**

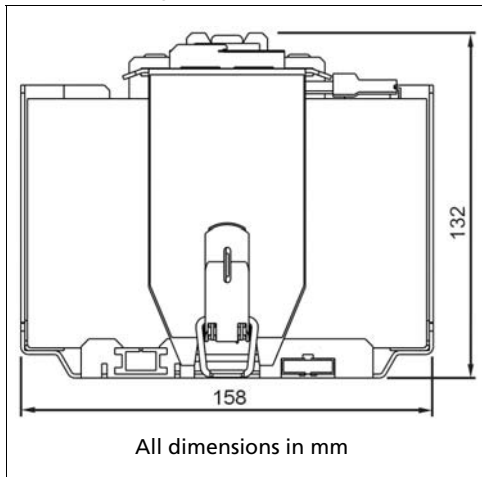

Fig. 15-2 **Side view**

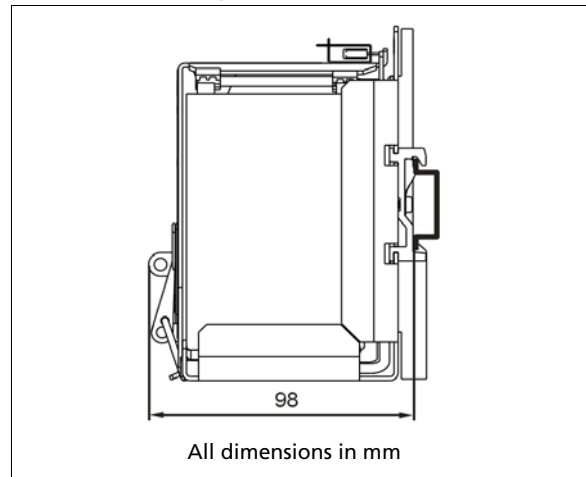
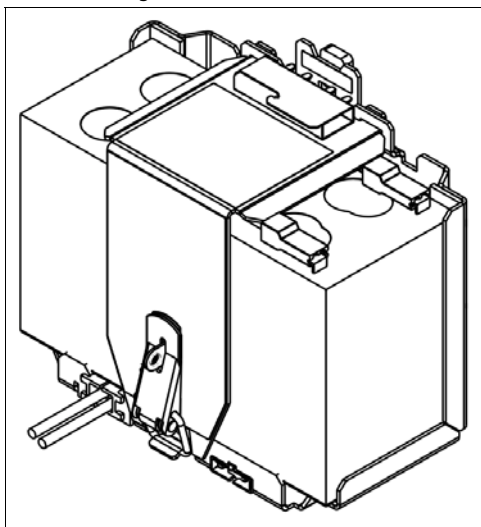

Fig. 15-3 **Isometric view**



### 16. WALL/PANEL MOUNTING

Panel/ wall mounting is possible by detaching the DIN-Rail brackets

Fig. 16-1 Panel/ wall mounting – Removing the aluminium brackets and plastic slide

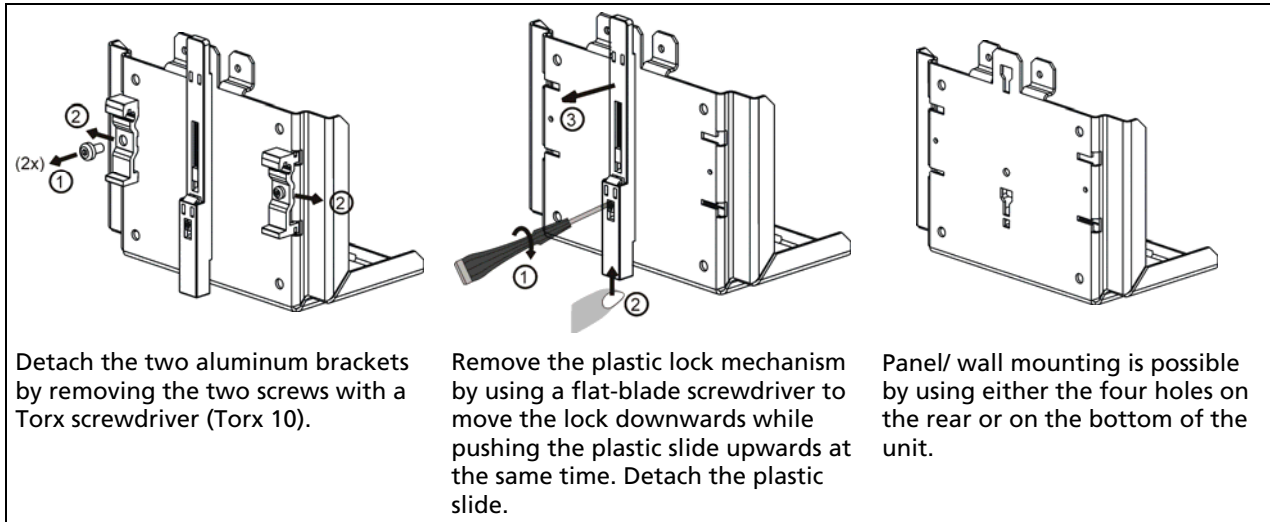

Fig. 16-2 Hole pattern for wall mount

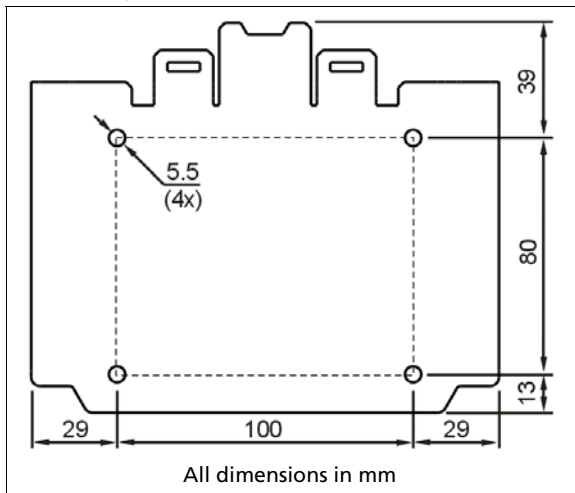
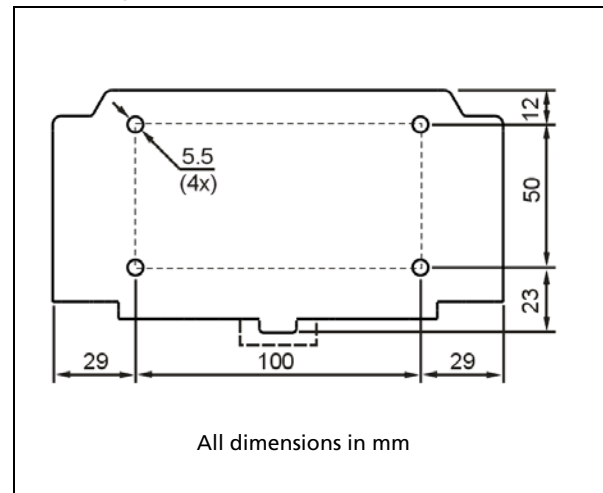

Fig. 16-3 Hole pattern for bottom mount



### 17. RECOMMENDATIONS FOR A LONG BATTERY LIFE

#### Temperature:

The temperature has the most impact on the service life. The hotter the temperature, the earlier the wear-out phase of the battery begins. The wear-out results in a degradation of battery capacity. Place the battery module in a cool location, e.g. near the bottom of the control cabinet. Do not place the battery module near heat generating devices. Do not overcharge batteries!

Fig. 17-1 Service life (according to EUROBAT) vs. ambient temperature, typ.

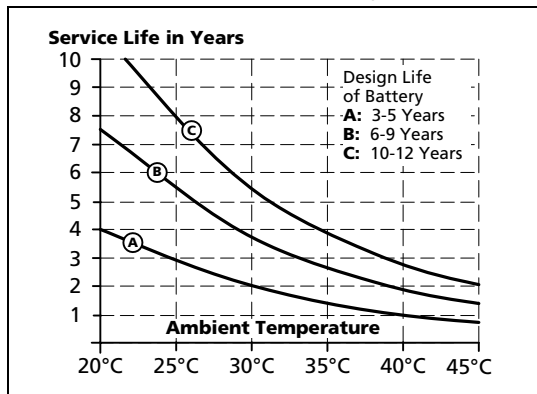

#### Number of discharge cycles and depth of discharge:

Do not discharge batteries more than necessary. Set buffer time limiter to the required buffer time. The number, as well as the depth of discharging cycles is limited. A replacement of the battery might be necessary earlier.

When choosing the battery capacity, always try to get the next higher capacity than required. The depth of discharge reduces the service life of the battery and limits the number of cycles.

Fig. 17-2 Battery degradation vs. discharging cycles, typ.

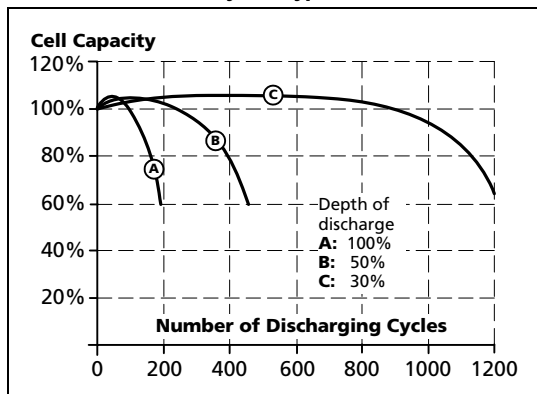

#### Store batteries fully charged

Do not store discharged batteries. Keep batteries fully charged!

Charge retention is important to get the longest battery life. Stored batteries which are not fully charged age faster than charged batteries. Batteries which are not in use should be recharged at least once a year. The higher the ambient temperature, the shorter the charging interval. At storage temperatures higher than 30°C, recharging should be done at least every nine months.

### 18. MOUNTING ORIENTATIONS

The standard mounting orientation is the vertical installation onto a flat surface.

Fig. 18-1 **Standard mounting orientation**

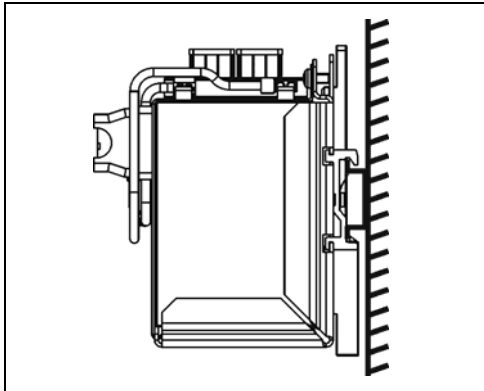

The following mounting orientations are also allowed:

Fig. 18-2 **Allowed mounting orientations**

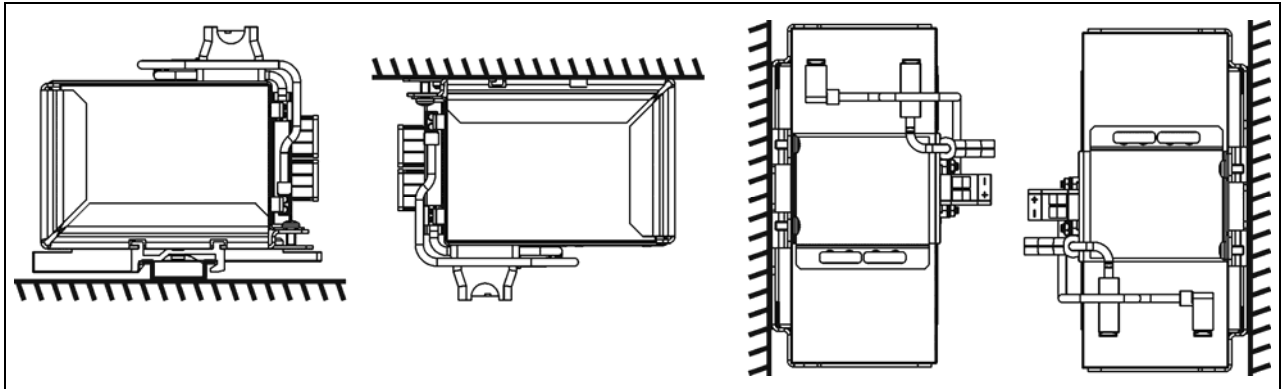

Do not use the battery module in an upside down position:

Fig. 18-3 **Forbidden mounting orientation**

